

OLIVER ARCHITECTURE



MATT FABER BA(Hons)Arch PG Dip Cons MCIAT

Graduated with BA (Hons) from the Leicester School of Architecture in 1994. Obtained a Post Graduate Diploma in Architectural Stonework Conservation at Bournemouth University 1996.

Worked as an Architectural Stone Conservator (with an architectural background). Workload soon expanded to cover most building materials and a variety of construction techniques. Gained 12 years post qualification experience on site, working for many of the country's leading conservation contractors including running own building conservation firm. Moved back into the world of architecture in 2008. Achieving Chartered Architectural Technologist MCIAT status in 2013.



St. Lawrence, Evesham

Working as a Technologist for several Midlands-based conservation architects exclusively on conservation and heritage projects including 2 years as a building surveyor for the National Trust with responsibilities for portfolios in Warwickshire, South Worcestershire and Northamptonshire.



Birmingham Oratory Library

Member of SPAB & ICON. Has demonstrated traditional buildings techniques at lime and technical days for the SPAB and Birmingham City University, and is often called on to offer guidance to contractors and volunteers on site on subjects such as lime, mortars, plastering and stonework. Technical support to colleagues across projects as well as running projects on site. Recently joined Lichfield DAC as an Architectural Advisor.

Specialises in the conservation, repair and reuse of historic, traditional buildings, monuments and historic landscapes, with traditional and also environmentally friendly and sustainable building methods and materials.



St. Chad, Bishops Tachbrook

Experience is varied but particularly in Ecclesiastical, Historic Houses, Timber Framed Buildings, Landscapes / Parkland Structures and Monuments. Amongst a keen interest in Conservation and Ecclesiastical architecture, has a soft spot for Terracotta and Iron Structures.

Recent Projects that I have worked on include:

National Trust Properties and Estates

Baddesley Clinton, Canons Ashby, Coughton Court, Charlecote Park
- Conservation, repairs and maintenance, fire protection works

Churches

St Lawrence, Evesham, Worcestershire (Churches Conservation Trust) – lias stone conservation and repointing to Tower, grade II*

St Chad, Bishops Tachbrook, Warwickshire - re-roofing aisle, grade I

Birmingham Oratory - repairs to the House north wing and Cardinal Newman's Library, conservation of the interior of Cardinal Newman's study, grade II*

All Saints, Small Heath Birmingham – external repairs to the fabric, grade II*



Coughton Court, Warwickshire

Oxford Colleges

Magdalen College - 1-7 Longwall Street, up-grading of student facilities, re-rendering and repairs to the C17th timber frame, grade II



1-7 Longwall Street, Oxford



Museum of the Gorge, Ironbridge



Brierley Hill War Memorial

Magdalen College Chapel- repairs and alterations to the organ chamber and screen to accept the installation of a new organ and casing, grade I
 Oriol College – refurbishment and upgrade of student facilities, grade I.

Museums

Soho House, Birmingham (Birmingham Museums & Arts Gallery) – condition survey, grade I
 Aston Hall, Birmingham (BMAG) - repairs to the South Lodge and Classroom Range, grade I
 Museum of the Gorge, Ironbridge Gorge Museums Trust - repairs and re-roofing, grade II*, World Heritage Site
 Jackfield Tile Museum (IGMT) - condition survey, grade II*
 Coalport China Works (IGMT) - condition survey, grade II*

Heritage Action Zone Grants

Brierley Hill War Memorial, West Midlands – conservation repairs to monument, and associated improvements to its setting, grade II
 Rankin Club, Leominster - repairs to the façade, reinstatement of slate roofs and sash windows, grade II

Historic Parks and Landscapes

St Paul’s Walden Bury, Hertfordshire - survey and repairs to C18th walled garden, registered park and garden, grade I

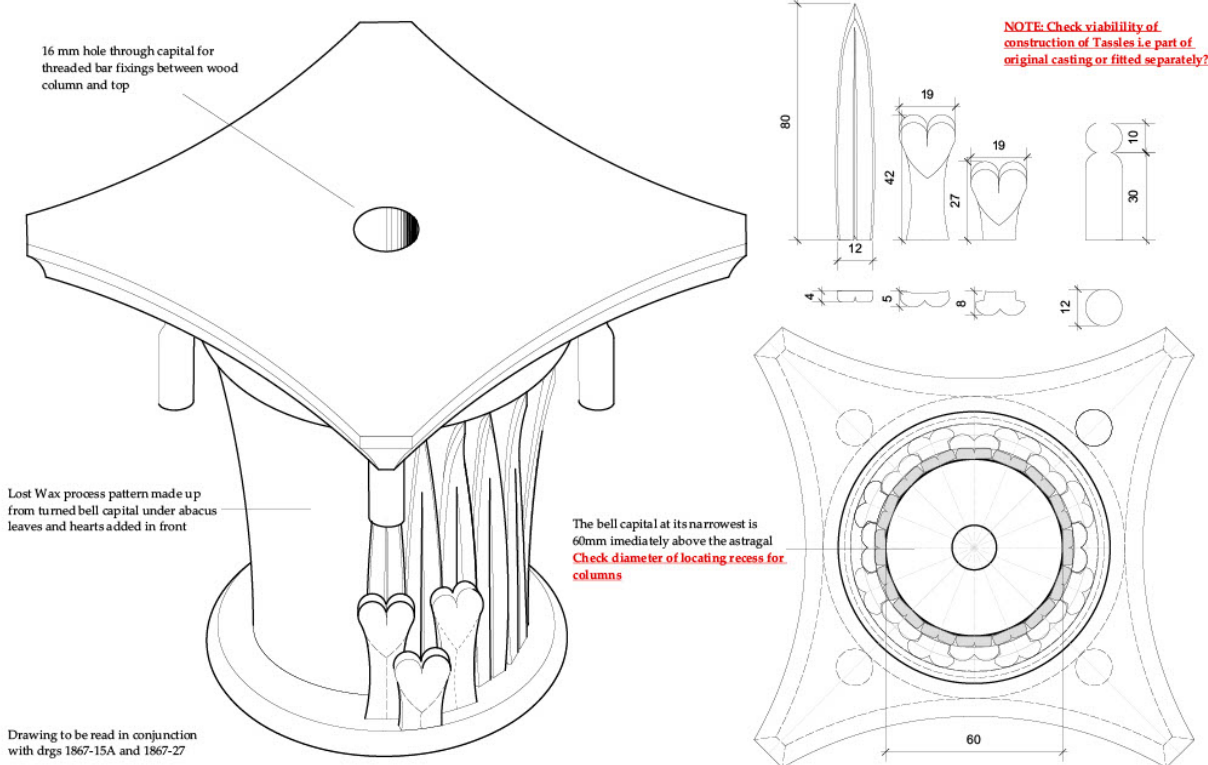

NOTE: Check viability of construction of Tassles i.e part of original casting or fitted separately?

Drawing to be read in conjunction with drgs 1867-15A and 1867-27

This drawing is the copyright of Oliver Architecture Ltd.
 All dimensions are to be checked on site prior to commencing work.
 Scaled dimensions should not be taken from this drawing unless stated.
 Dimensions of new work are to be adjusted to suit the existing building as necessary.
 The contractor must not assume that the existing building is plumb, square or level.
 Prior to commencing work, all discrepancies are to be reported to the Architect.

Revisions:



OLIVER ARCHITECTURE LTD.
 The Coffin Works, 13-15 Fleet Street,
 Jewellery Quarter, Birmingham B3 1JP
 T: 0121 773 5002
 W: www.oliver-architecture.co.uk

Project	The Oratory, Birmingham Newman Shrine	Scale	1:10 A3	Job No.	1867
Drawing	Proposed Capital Isometric view sheet 1	Date	Aug 2019	Dwg. No.	26
Drawn	mgf	Rev.			